

DUTY MASTER ALTERNATING CURRENT MOTORS

SQUIRREL-CAGE INDUCTION
CAST IRON CONSTRUCTION

ENCLOSURE: TOTALLY ENCLOSED
MOUNTING: FOOT

FRAMES 364T-365T

COOLING: FAN COOLED

617428-032

D

C

B

A

D

C

B

A

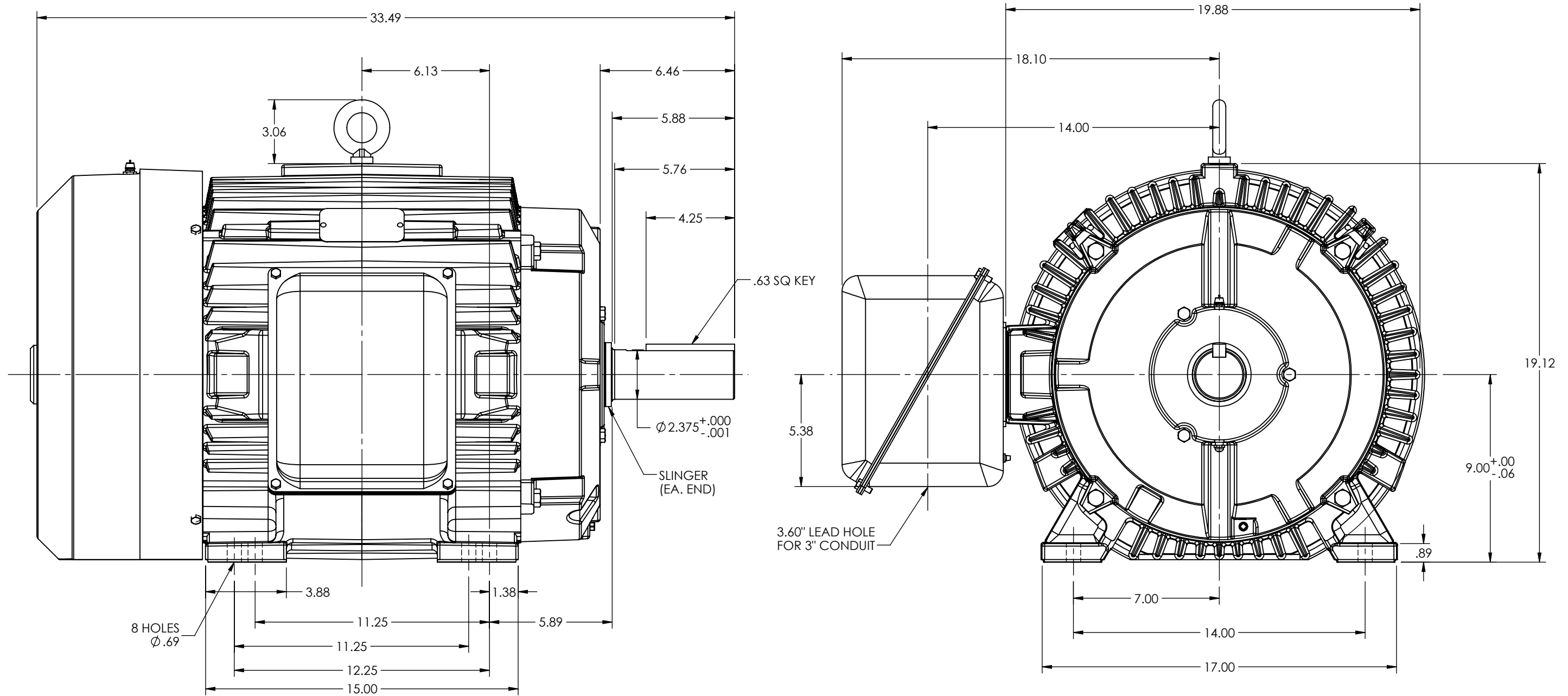

MAXIMUM PERMISSIBLE SHAFT RUNOUT WHEN MEASURED
AT END OF SHAFT EXTENSION IS .003 T.I.R.

WEIGHT (LBS): 364T = 800
365T = 840

MOTOR WEIGHTS MAY VARY BY 15% DEPENDING UPON RATING.

CUSTOMER IS RESPONSIBLE FOR DETERMINING THAT BALDOR'S PRODUCT WILL PERFORM SUITABLY IN THE INTENDED APPLICATION

REV. DESC: 3" CONDUIT WAS 3" NPT			
REV: A	VERSION: 01	REVISED: 12:07:58 04/25/2017	TDR: 000001025245
MODEL NO. 617428-032			REF:
BY: RAGEC			B

BALDOR

DIM SHT TEFC 364-365T FT MTG W/SLINGERS, GRSSR AND RELIEF

617428-032

8 7 6 5 4 3 2 1