



Tigear-2[®] Accessory Kit Instruction Manual

These instructions must be read thoroughly before installation or operation. This instruction manual was accurate at the time of printing. Please see dodgeindustrial.com for updated instruction manuals.

WARNING: To ensure the drive is not unexpectedly started, turn off and lock-out or tag power source before proceeding. Failure to observe these precautions could result in bodily injury.

WARNING: All products over 25 kg (55 lbs) are noted on the shipping package. Proper lifting practices are required for these products.

WARNING: Because of the possible danger to person(s) or property from accidents which may result from the improper use of products, it is important that correct procedures be followed. Products must be used in accordance with the engineering information specified in the catalog. Proper installation, maintenance and operation procedures must be observed. The instructions in the instruction manuals must be followed. Inspections should be made as necessary to assure safe operation under prevailing conditions. Proper guards and other suitable safety devices or procedures as may be desirable or as may be specified in safety codes should be provided, and are neither provided by Dodge[®] nor are the responsibility of Dodge. This unit and its associated equipment must be installed, adjusted and maintained by qualified personnel who are familiar with the construction and operation of all equipment in the system and the potential hazards involved. When risk to persons or property may be involved, a holding device must be an integral part of the driven equipment beyond the speed reducer output shaft.

BOLT-ON BASE KIT

Install the detachable base with the smooth side of the base facing the mounting surface of the reducer. Install the screws supplied in the kit and tighten all screws to two-thirds of the appropriate value listed. Then tighten all screws to the final torque given.

NOTE: If washers are supplied, it is extremely important to use them with the screws when attaching the base.

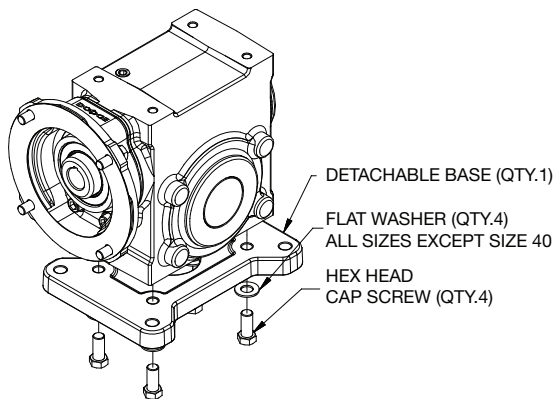

Reducer Size	Bolt or Screw Size	Tightening Torque (ft-lb)
13	1/4-20	8
15	1/4-20	8
17	5/16-18	17
20	3/8-16	30
23	3/8-16	30
26	3/8-16	30
30	7/16-14	48
35	7/16-14	48
40	5/8-11	130
47	5/8-11	130

STRAIGHT BORE BUSHING KIT

Loosen the six set screws in the hollow bore shaft and insert the keyed bushing and supplied key into the side of the hollow bore shaft that will be closest to the driven equipment. Line up the clearance hole in the bushing with the set screw. Insert the straight bore bushing into the hollow bore shaft on the opposite side of the reducer and line up the two clearance holes in the bushing with the set screws. Apply anti-seize compound to the driven shaft and slide the reducer onto the driven shaft. Hand tighten one of the set screws and then hand tighten a set screw in the same position on the opposite side of the reducer. This will take up the clearance between the shaft and reducer to the same side and reduce wobble. Continue the alternating hand tightening until all the set screws have been tightened. After all the set screws have been hand tightened, use a torque wrench to tighten the set screws to the values in the chart below. The 10-32 set screw over the key should be tightened to 3 ft-lb.

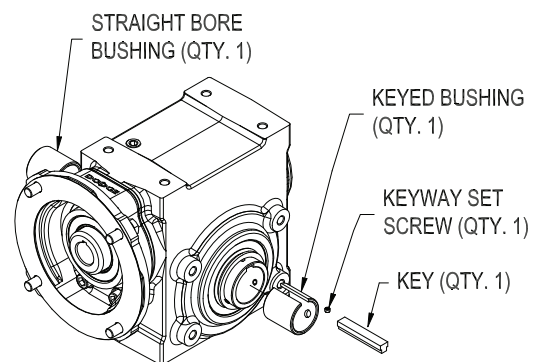

Reducer Size	Bolt or Screw Size	Tightening Torque (ft-lb)
20	1/4-28	8
23	1/4-28	8
26	1/4-28	8
30	5/16-24	15
35	5/16-24	15

RISER BLOCK KIT

Place the riser blocks between the reducer and the bolt-on base. The riser blocks may be supplied either as two pieces with two holes each or as one piece with four holes. If the two piece style riser block has offset holes, place the riser block on the reducer to minimize the amount the riser block hangs off the ends of the reducer (**install riser blocks as shown in View A, not View B**). Install the screws supplied in the kit and tighten all screws to two-thirds of the appropriate value listed. Tighten all screws to the final torque given.

WARNING: If washers are supplied, it is extremely important to use them with the screws when attaching the base. The supplied screws MUST be tightened to the torque values listed below. The torque values listed are based upon the use of the supplied fasteners which are pre-coated with a thread locker that can only be used once. If a screw is removed during initial installation, the screw must be discarded and replaced with a new pre-coated screw. Failure to follow the above procedure may result in serious injury or death from falling items.

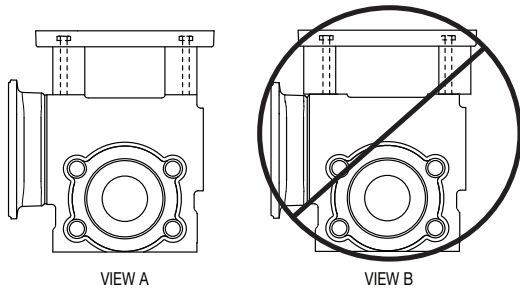
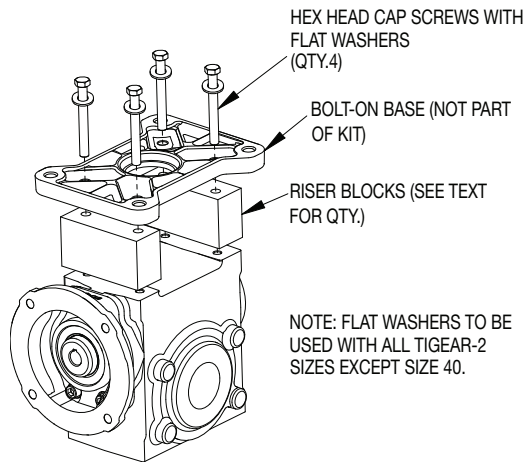

Reducer Size	Bolt or Screw Size	Tightening Torque (ft-lb)
13	1/4-20	8
15	1/4-20	8
17	5/16-18	17
20	3/8-16	30
23	3/8-16	30
26	3/8-16	30
30	7/16-14	48
35	7/16-14	48
40	5/8-11	130
47	5/8-11	130

OUTPUT FLANGE KIT

INSTALLATION ON BEARING COVER SIDE: Remove and discard the four retaining screws on the outside corners of the bearing cover. **Do not remove the two smaller screws.** Install the output flange over the bearing cover. Install the supplied longer screws, flat washers, and lock washers and tighten all screws to two-thirds of the appropriate value listed below. Tighten all screws to the final torque value given.

INSTALLATION ON SIDE WITHOUT BEARING COVER: Install the output flange and the supplied shorter screws, flat washers, and lock washers. Tighten the screws to the tightening torque values listed in the table below.

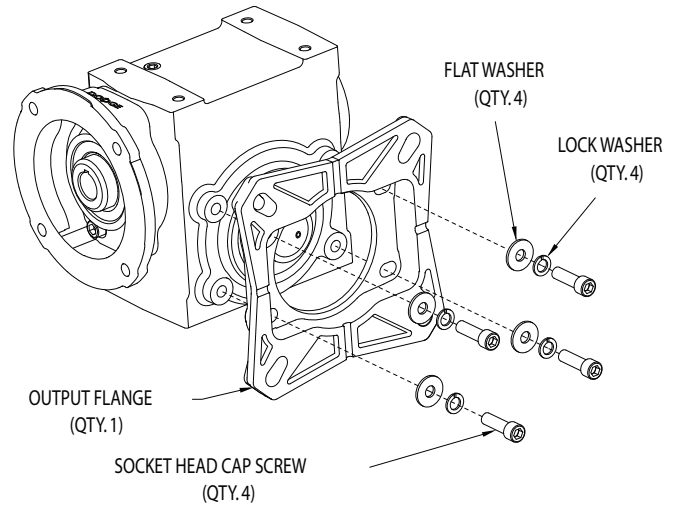

Reducer Size	Bolt or Screw Size	Tightening Torque (ft-lb)
17	5/16-18	17
20	5/16-18	17
23	3/8-16	30
26	3/8-16	30
30	7/16-14	48
35	7/16-14	48

OUTPUT BRACKET KIT

Attach the output bracket to the reducer bottom using the supplied screws and lock washers. If a spacer is supplied, install the spacer between the reducer top and output bracket and use the longer two bolts supplied. Install the supplied screws and lock washers. Tighten all screws to the tightening torque values listed in the table below.

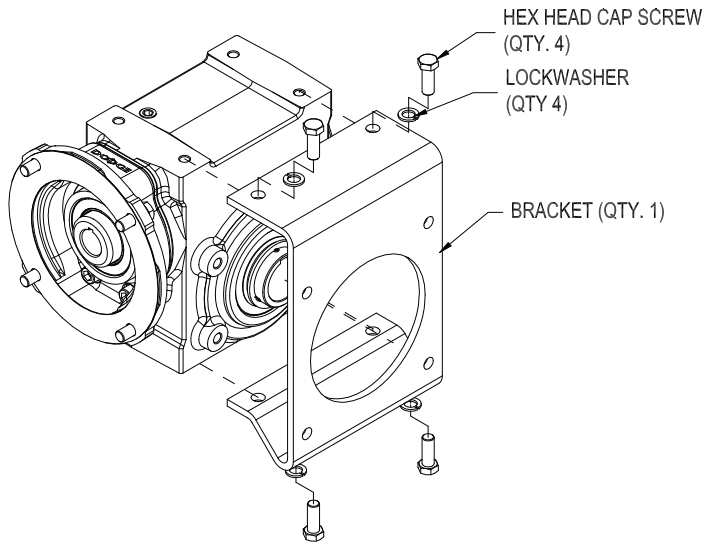

Reducer Size	Bolt or Screw Size	Tightening Torque (ft-lb)
13	1/4-20	8
15	1/4-20	8
17	5/16-18	17
20	3/8-16	30
23	3/8-16	30
26	3/8-16	30
30	7/16-14	48
35	7/16-14	48

OUTPUT SAFETY COVERS

INSTALLATION ON BEARING COVER SIDE (applies to hollow shaft units only): Remove and discard the four retaining screws and lock washers on the outside corners of the bearing cover. **Do not remove the two smaller screws.** Using the longer screws supplied in the kit, install the safety cover with the lock washers sandwiched between two larger flat washers on each outside corner of the bearing cover as depicted in the diagram below. Be certain to orient the drain port in a downward position if possible. Torque the screws to the values listed in the table below.

INSTALLATION ON SIDE WITHOUT BEARING COVER (applies to hollow shaft units only): Using the shorter screws supplied in the kit, install the safety cover with the lock washers sandwiched between two larger flat washers on each outside corner of the bearing cover as depicted in the diagram below. Be certain to orient the drain port in a downward position if possible. Torque the screws to the values listed in the table below.

NOTE: The lock washers will fit inside the holes at the four corners of the safety cover.

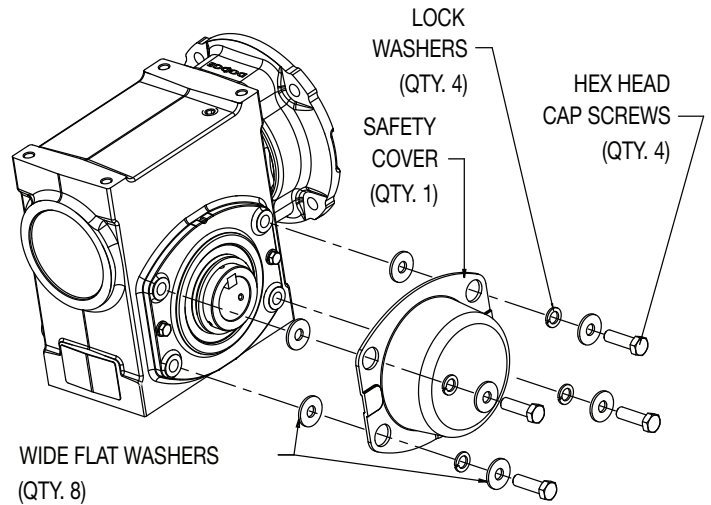

Reducer Size	Bolt or Screw Size	Tightening Torque (ft-lb)
17	5/16-18	17
20	5/16-18	17
23	3/8-16	30
26	3/8-16	30
30	7/16-14	48
35	7/16-14	48
40	5/8-11	130

TRANSITION KIT

Position the transition base on the reducer with the counter bored holes facing away from the reducer. Insert the supplied socket head screws and lock washers and tighten the screws to the tightening torque values listed in the below table. Position the detachable base on the transition base (if used) and insert the hex head screws. Tighten the screws to the tightening torque values listed in the table below.

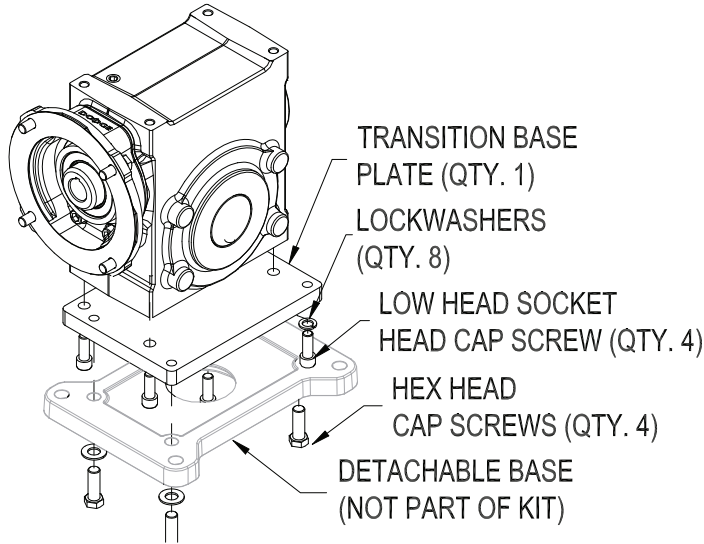

Reducers	23→26	26→30	30→35
Transition Base to Reducer Screw Size	3/8-16	3/8-16	7/16-14
Socket Head Screw Tightening Torque (ft-lb)	30	30	48
Detachable Base to Transition Base Screw Size	3/8-16	7/16-14	7/16-14
Hex Head Screw Tightening Torque (ft-lb)	30	48	48

J-MOUNT BASE KIT

Install the J-mount brackets on the reducer. Insert and hand tighten the supplied screws and lock washers. Install the reducer in the application and insert and hand tighten the foundation bolts. Tighten the J-mount bolts and lock washers on the reducer to the values listed below. Tighten the foundation bolts.

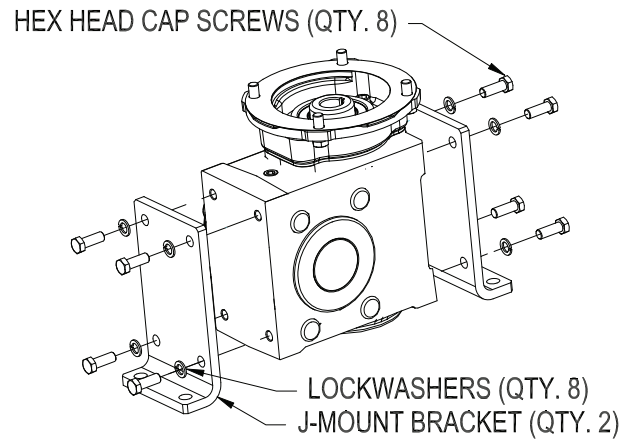

Reducer Size	Bolt or Screw Size	Tightening Torque (ft-lb)
13	1/4-20	8
15	1/4-20	8
17	5/16-18	17
20	3/8-16	30
23	3/8-16	30
26	3/8-16	30
30	7/16-14	48
35	7/16-14	48

PLUG-IN SHAFT KIT

Install a snap ring on the plug-in shaft near the shaft extension end. Insert the bore key into the key seat in the plug-in shaft. Remove the two keyway set screws and loosen the remaining four set screws in the hollow bore shaft in the reducer. (The keyway set screws may be used but are not required.) Holding the plug-in output shaft extension, slide the plug-in shaft into the hollow bore. Install the second snap ring into the groove in the plug-in shaft on the non-drive end. Hand tighten one of the four set screws and then hand tighten a set screw in the same position on the opposite side of the reducer. Continue to alternate tightening the set screws until all four set screws have been hand tightened. After all the set screws have been hand tightened, use a torque wrench to tighten the set screws to the values in the table below.

NOTE: Apply a thread-locking compound to the raised diameters on the plug-in shaft before inserting into the reducer for improved performance.

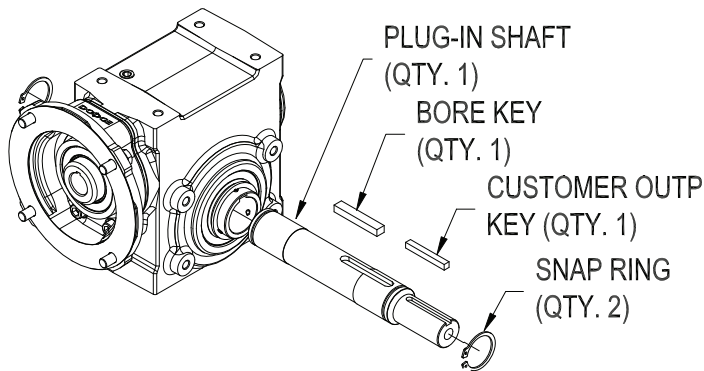

Reducer Size	Bolt or Screw Size	Tightening Torque (ft-lb)
13	1/4-28	8
15	1/4-28	8
17	1/4-28	8
20	1/4-28	8
23	1/4-28	8
26	1/4-28	8
30	5/16-24	15
35	5/16-24	15
40	3/8-24	28
47	3/8-24	28

TIE ROD KIT

Assemble tie rod assembly components—right-hand threaded rod end, right-hand nut, turn buckle, left-hand threaded rod end and left-hand nut. The tie rod mounting bracket can be located on the top or bottom of the reducer. Using the diagram below as a reference, position the bracket so the tie rod assembly is on the side of the reducer closest to the driven equipment. Install the mounting bracket cap screws and lock washers and tighten to the specified torque value below. Assemble the tie rod assembly onto the mounting bracket and the fulcrum onto the tie rod assembly using the supplied hardware (cap screws, lock washers and nuts). Hardware should only be hand-tight. Install the fulcrum at an angle not more than 30 degrees from the motor centerline using customer supplied hardware. The tie rod assembly length can be adjusted by rotating the tie rod assembly turn buckle. Tighten the tie rod assembly mounting hardware. Tighten tie rod assembly jam nuts against the turn buckle to lock the assembly's length.

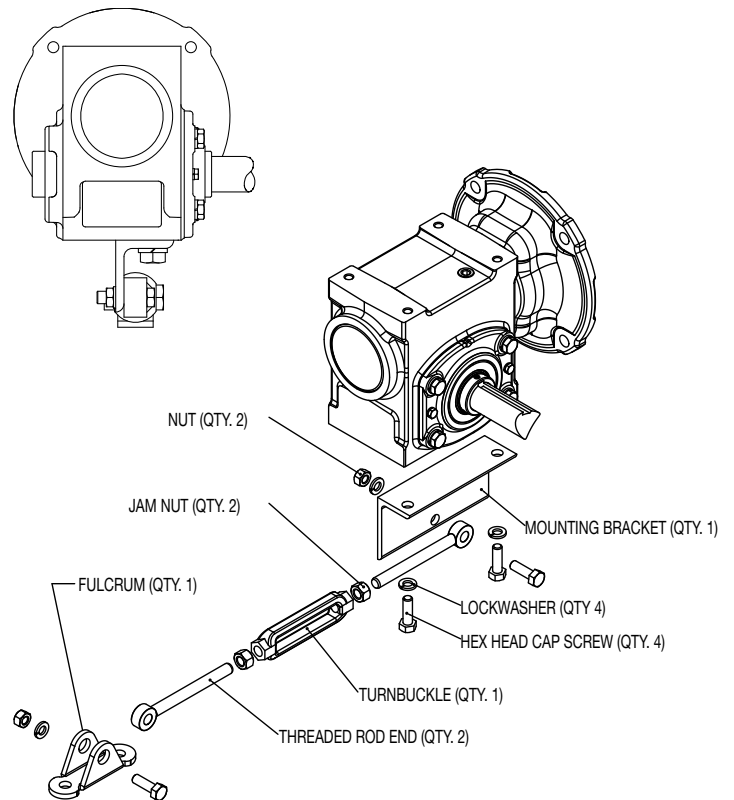

Reducer Size	Bolt or Screw Size	Tightening Torque (ft-lb)
13	1/4-20	8
15	1/4-20	8
17	5/16-18	17
20	3/8-16	30
23	3/8-16	30
26	3/8-16	30
30	7/16-14	48
35	7/16-14	48
40	5/8-11	130
47	5/8-11	130

MOTOR ADAPTER KIT

Locate the reducer on a secure surface with the input shaft facing up. Loosen the set screws in both coupling halves. Position the reducer coupling half so that it is flush with the end of the reducer input shaft. Insert the reducer key and tighten the set screw(s). Coupling hubs may contain one or two set screws. Rotate the coupling hub one complete revolution to verify the number of set screws. Torque all set screws per Table 2 below. A hex socket and extension, not a T-handle wrench, must be used to tighten the set screws. Install the o-ring on the motor adapter and install the motor adapter on the reducer using the motor adapter bolts and copper washers. Tighten the motor adapter bolts to the torque values listed in Table 1 below. Install the gasket between the motor and motor adapter flange. To help prevent pinching the gasket, place and align the gasket onto the motor face for the 56 and 140TC frame motors and onto the motor adapter face for the 180, 210, and 250TC frame motors. A small amount of grease or other suitable product can be placed on the gasket in three locations to temporarily hold gasket into place.

NOTE: On 210 and 250 frame motor adapter kits, an adapter plate and additional gasket may be supplied. Place the adapter plate onto the gasket on the motor adapter and then place the additional gasket onto the adapter plate.

Insert the elastomeric element into the reducer coupling half. Place the motor coupling half onto the elastomeric element. Install the motor key into the motor shaft. Stake the key into the motor shaft keyway using a punch or small chisel. Align the motor shaft key with the coupling half keyway and slowly lower the motor until the motor flange contacts the motor adapter or the adapter plate face. No visible gap should be present. Do not use the motor mounting bolts to pull the motor onto the motor adapter. Install the motor mounting bolts and lock washers. Torque the motor mounting bolts per Table 3 below. Looking through the access hole, verify that the coupling faces are in full contact with the coupling elastomeric element. To set the required gap, insert a .010-.030" shim or feeler gauge between the elastomeric element and the motor coupling half. An insufficient or excessive gap can cause premature coupling failure. Tighten the motor coupling set screw(s). Coupling hubs may contain one or two set screws. Rotate the coupling hub one complete revolution to verify the number of set screws. Torque all set screws per Table 2 below. Install access hole plug.

NOTE: The Tigear-2 three piece couplings are sourced from two manufacturers. Tigear-2 reducers may contain either manufacturer's coupling.

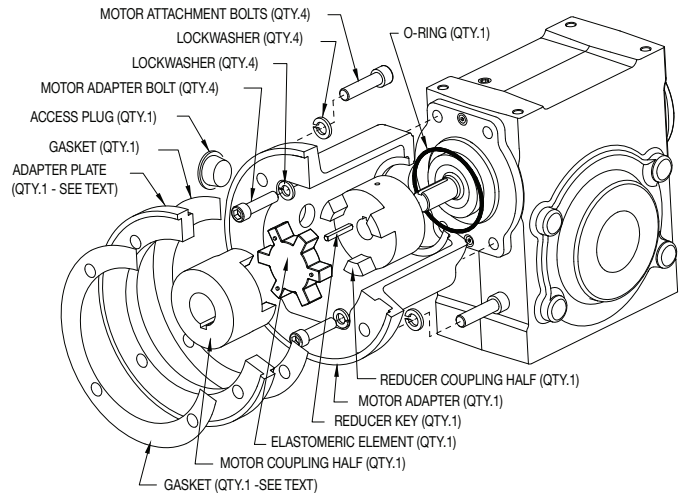

Reducer Size	Bolt or Capscrew Size	Tightening Torque (non-lubricated)
13 - 20	5/16 - 18	17 ft-lb
23 - 30	3/8 - 16	30 ft-lb
35 - 47	7/16 - 14	48 ft-lb

Reducer Size	C-Face	Coupling Size	Set Screw Size	Hex Key Size	Tightening Torque
13A - 30A	56C	L075	1/4-20 x 5/16	1/8	78 - 87 in-lb (6.5 - 7.3 ft-lb)
13A - 15A	140TC				
35A	56C	L090	1/4-20 x 5/16	1/8	78 - 87 in-lb (6.5 - 7.3 ft-lb)
17A - 35A	140TC				
40A - 47A	140TC	L099	5/16-18 x 3/8	5/32	150 - 165 in-lb (12.5 - 13.8 ft-lb)
23A - 47A	180TC				
35A - 47A	210TC	L110	3/8-16 x 1/2	3/16	260 - 290 in-lb (21.7 - 24.2 ft-lb)

Reducer Size	C-Face	Bolt or Capscrew Size	Tightening Torque (non lubricated)
13 - 40	56C	3/8 -16	23 ft-lb
	140TC		
23 - 47	180TC	1/2 - 13	57 ft-lb
	210TC		
	250TC		

GRIP TIGHT BUSHING KIT

Clean the driven shaft and bore of the bushing inner sleeve to remove any oil, grease, or dirt. Insert the bushing inner sleeve into the bushing outer sleeve/nut assembly.

NOTE: If your Grip Tight bushing kit arrives without the lock nut preinstalled, please return the kit to your local distributor for one where the lock nut has already been installed on the outer sleeve.

If the inner sleeve threads do not engage with the lock nut, hold the assembly in your hand with the lock nut towards you. Hit or rap on the inner sleeve with a soft rubber mallet or the palm of your other hand to seat the threads against the lock nut. Rotate the nut clockwise until the threads in the nut engage the threads in the inner sleeve. Slide the bushing assembly into the driven shaft with the lock nut closest to the driven device and install a key into the bushing.

NOTE: Using a key in the bushing(s) is the preferred arrangement but is not required if two bushings are used. Keys are ALWAYS required for brake motor applications. Two bushings are recommended on size 35 and larger reducers. On smaller reducers, if only one bushing is used, it is recommended a second bushing be temporarily used to support the reducer during the installation of the desired bushing.

Loosen the six hollow bore set screws and slide the reducer onto the shaft bushing. Support the reducer to keep it from swinging out of position.

WARNING: Failure to support the reducer may result in injury.

If two bushings are being used, install the second bushing into the reducer on the opposite side of the reducer hollow bore. When the reducer is located in the correct location, rotate the nut on the bushing closest to the driven device clockwise with a spanner wrench or a pair of large pliers until it is snug and the reducer cannot be slid along the shaft. Tighten the nut and additional $\frac{3}{4}$ to 1 turn on size 23 and 26 reducers, and additional 1 to 1- $\frac{1}{4}$ turns on size 30 and 35 reducers and an additional 1- $\frac{1}{2}$ to 2 turns on size 40 and 47 reducers. Tighten the set screw located on the nut. Repeat the nut tightening procedure for the other bushing if used. Tighten the six hollow bore set screws.

WARNING: Failure to properly tighten the bushing assemblies may cause equipment failure and personal injury.

Install the torque arm or other mounting bracket to keep the reducer from rotating about the driven shaft.

NOTE: If the bushing rotates while tightening the nut on dual bushing applications without keys, insert a set screw into the hollow bore shaft and tighten the screw until it extends into the keyway in the bushing inner sleeve.

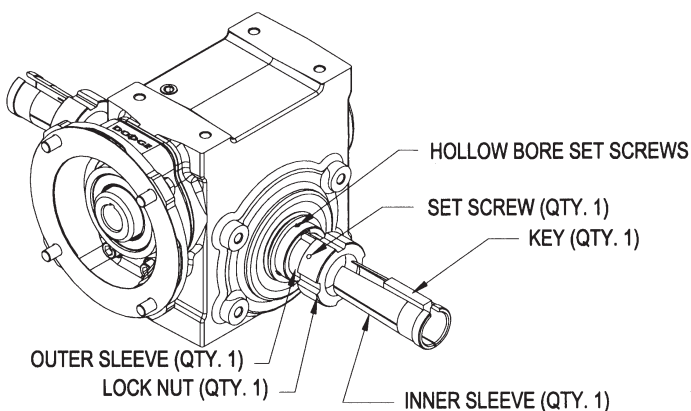

TORQUE ARM BRACKET INSTALLATION

NOTE: The banjo style torque arm bracket should be mounted on the reducer side closest to the driven equipment.

TORQUE ARM BRACKET INSTALLATION ON BEARING COVER SIDE: Remove and discard the four retaining capscrews located on the outside corners of the bearing cover. **Do not remove the two smaller capscrews.** Locate the torque arm bracket in the desired position. The torque arm bracket can be positioned in 45 degree increments. Using the supplied longer capscrews, lock washers, flat washers, and spacers, install the bracket onto the bearing housing. The spacers are located between the bearing cover and the torque arm bracket. Install all four capscrews, spacers, and washers before tightening the capscrews. Visually center the bracket bore ID with the output shaft hub OD and lightly tighten the capscrews. Torque the four capscrews in a crossing pattern to $\frac{2}{3}$ the recommended torque value listed below. Tighten the four capscrews to the recommended torque value.

TORQUE ARM BRACKET INSTALLATION ON SIDE WITHOUT BEARING COVER: Locate the torque arm bracket in the desired position. The torque arm bracket can be positioned in 45 degree increments. Using the supplied shorter capscrews, lock washers, flat washers, and spacers, install the bracket onto the reducer. The spacers are located between the reducer housing bosses and the torque arm bracket. Install all four capscrews, spacers, and washers before tightening the capscrews. Visually center the bracket bore ID with the output shaft hub OD and lightly tighten the capscrews. Torque the four capscrews in a crossing pattern to $\frac{2}{3}$ the recommended torque value listed below. Tighten the four capscrews to the recommended torque value.

TORQUE ARM BRACKET INSTALLATION TO CUSTOMER'S STRUCTURE: Prepare the reducer's hollow output shaft and selected bushing kit (if required) for mounting onto the customer's shaft. Follow the installation instructions for the selected bushing kit provided in this manual. The straight bore bushing kit and the grip tight bushing kit installation instructions are on page 1 and page 7, respectively.

On the frame side of the torque arm bracket, install the inner rubber isolator bushing half into bracket's small bore ID. Slide the Tigear-2 reducer onto the shaft until the inner torque arm bushing touches the customer's structure. The frame must completely support/back up the 1.88" diameter bushing. Do not tighten the reducer onto the customer's shaft until after the torque arm bushing has been assembled and the $\frac{1}{2}$ " nut has been tightened. **Caution: To prevent injury, use a temporary restraining device to hold the reducer onto the shaft during the torque arm bracket assembly.** Install a $\frac{1}{2}$ " flat washer onto the customer supplied grade 5, $\frac{1}{2}$ " diameter bolt and insert the bolt/washer combination through the customer's frame and the torque arm bracket inner bushing. The customer-supplied $\frac{1}{2}$ " bolt length will be determined by the customer's frame thickness. The $\frac{1}{2}$ " bolt should be partially threaded. **Do not use a fully threaded bolt.** On the reducer side of the torque arm bracket, install the $\frac{7}{8}$ " flat washer, the outer isolator bushing half with the bevel side away from the $\frac{7}{8}$ " flat washer, the $\frac{5}{8}$ " flat washer, the $\frac{1}{2}$ " flat washer, and the $\frac{1}{2}$ " lock washer. Verify the bushing halves and hardware components are properly aligned. Apply 243 Loctite to the $\frac{1}{2}$ " bolt threads and install the $\frac{1}{2}$ " hex nut. Tighten the hex nut to 200 in-lb torque.

Tighten the reducer onto the customer's shaft in accordance with the reducer or the selected bushing installation instructions. The straight bore bushing kit and the grip tight bushing kit installations instructions are on page 1 and page 7, respectively. Remove temporary restraining device.

Reducer Size	Bolt or Screw Size	Tightening Torque (ft-lb)
17	5/16-18	17
20	5/16-18	17
23	3/8-16	30
26	3/8-16	30
30	7/16-14	48
35	7/16-14	48

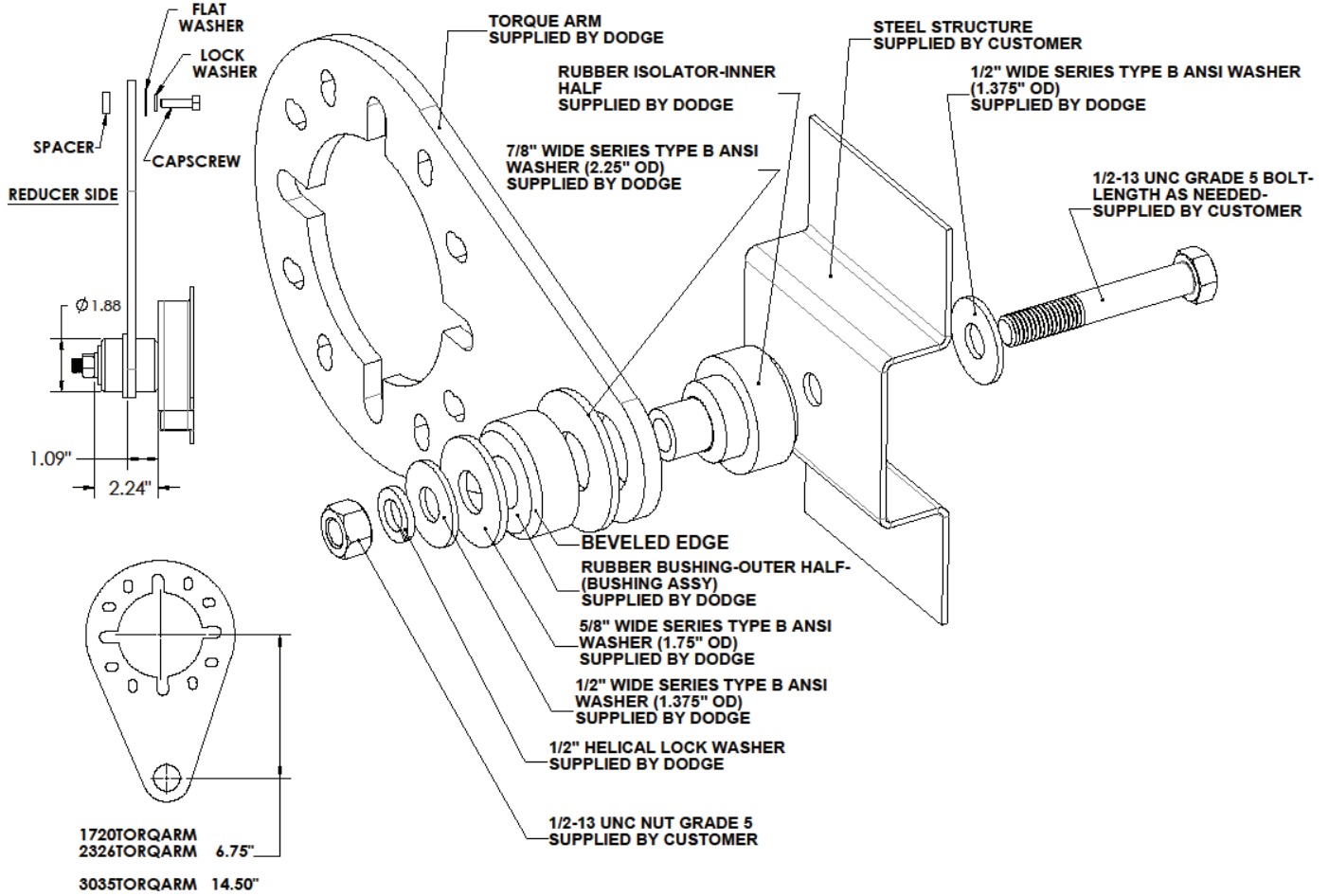

Dodge Industrial, Inc.
1061 Holland Road
Simpsonville, SC 29681
+1 864 297 4800



* 1 6 6 1 - 0 2 2 2 *