

Maximum Rating Tables

Size 815 • GR, NH Series



Style B

Style H

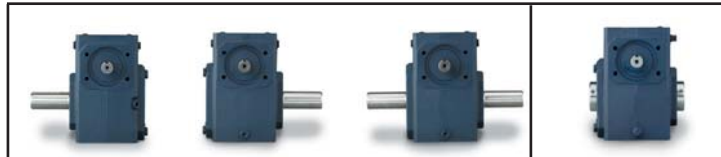

Size 815

Ratio	Input RPM	Output RPM	Input HP	Output HP	Output Torque (lb-in)	Left Hand Catalog No.	Right Hand Catalog No.	Double Extension Catalog No.	Hollow Output Catalog No.*
5	2500	500	2.310	2.151	271	_8150001	_8150013	_8150025	_8150501.10
	1750	350	1.939	1.794	323				
	1170	234	1.537	1.408	379				
7.5	100	20	0.235	0.167	526	_8150002	_8150014	_8150026	_8150502.10
	2500	333	1.785	1.619	306				
	1170	156	1.205	1.068	431				
10	100	13	0.196	0.125	591	_8150003	_8150015	_8150027	_8150503.10
	2500	250	1.500	1.324	334				
	1170	117	1.014	0.869	468				
15	100	10	0.176	0.101	639	_8150004	_8150016	_8150028	_8150504.10
	2500	166	1.174	0.982	371				
	1170	116	1.003	0.826	446				
20	100	6.7	0.155	0.075	706	_8150005	_8150017	_8150029	_8150505.10
	2500	125	1.077	0.860	434				
	1170	87	0.919	0.719	518				
25	100	5.0	0.155	0.064	807	_8150006	_8150018	_8150030	_8150506.10
	2500	100	0.881	0.670	422				
	1170	70	0.752	0.559	503				
30	100	4.0	0.137	0.049	775	_8150007	_8150019	_8150031	_8150507.10
	2500	83	0.729	0.526	398				
	1170	46	0.602	0.431	580				
40	100	3.3	0.124	0.040	754	_8150008	_8150020	_8150032	_8150508.10
	2500	62	0.649	0.432	435				
	1170	29	0.456	0.279	601				
50	100	2.5	0.122	0.032	808	_8150009	_8150021	_8150033	_8150509.10
	2500	50	0.536	0.329	415				
	1170	23	0.379	0.211	569				
60	100	2.0	0.110	0.024	760	_8150010	_8150022	_8150034	_8150510.10
	2500	41	0.451	0.257	389				
	1170	19	0.321	0.165	532				
80	100	1.7	0.099	0.019	707	_8150011	_8150023	_8150035	_8150511.10
	2500	31	0.219	0.109	220				
	1170	14	0.176	0.073	314				
100	100	1.3	0.032	0.008	418	_8150012	_8150024	_8150036	_8150512.10
	2500	25	0.155	0.069	175				
	1170	11	0.126	0.046	248				
	100	1.0	0.024	0.005	328				

How To Build a Part Number For Size GR815 & NH815

1. Select partial catalog number from the selection table
2. Replace leading “_” with series code (GR, NH)

Example:

Grove Gear IRONMAN, style B, 5:1 ratio, left hand output
 GR-B815-5-L
 GR8150001

Single Reduction
Worm Gear Reducers

Double Reduction
Worm - Worm Gear Reducers

Double Reduction
Helical - Worm Gear Reducers

WASHGUARD® Reducers
and GEAR+MOTOR™

Ratio Multipliers

Accessories and
Additional Capabilities

Single Reduction
Worm Gear Reducers

Double Reduction
Worm - Worm Gear Reducers

Double Reduction
Helical - Worm Gear Reducers

WASHGUARD® Reducers
and GEAR+MOTOR™

Ratio Multipliers

Accessories and
Additional Capabilities

Style BM

Style HM

Style BMQ

Style HMQ



NEMA C Input Flange ▲	Left Hand Catalog No.	Right Hand Catalog No.	Double Extension Catalog No.	Hollow Output Catalog No.	Left Hand Catalog No.	Right Hand Catalog No.	Double Extension Catalog No.	Hollow Output Catalog No.	Ratio
56C 143-5TC	8150073 8150109	8150085 8150121	8150097 8150133	8150525.10 8150537.10	8150181 8150217	8150193 8150229	8150205 8150241	8150561.10 8150573.10	5
56C 143-5TC	8150074 8150110	8150086 8150122	8150098 8150134	8150526.10 8150538.10	8150182 8150218	8150194 8150230	8150206 8150242	8150562.10 8150574.10	7.5
56C 143-5TC	8150075 8150111	8150087 8150123	8150099 8150135	8150527.10 8150539.10	8150183 8150219	8150195 8150231	8150207 8150243	8150563.10 8150575.10	10
56C 143-5TC	8150076 8150112	8150088 8150124	8150100 8150136	8150528.10 8150540.10	8150184 8150220	8150196 8150232	8150208 8150244	8150564.10 8150576.10	15
56C 143-5TC	8150077 8150113	8150089 8150125	8150101 8150137	8150529.10 8150541.10	8150185 8150221	8150197 8150233	8150209 8150245	8150565.10 8150577.10	20
56C	8150078	8150090	8150102	8150530.10	8150186	8150198	8150210	8150566.10	25
48CZ 56C	8150043 8150079	8150055 8150091	8150067 8150103	8150519.10 8150531.10	8150151 8150187	8150163 8150199	8150175 8150211	8150555.10 8150567.10	30
48CZ 56C	8150044 8150080	8150056 8150092	8150068 8150104	8150520.10 8150532.10	8150152 8150188	8150164 8150200	8150176 8150212	8150556.10 8150568.10	40
48CZ 56C	8150045 8150081	8150057 8150093	8150069 8150105	8150521.10 8150533.10	8150153 8150189	8150165 8150201	8150177 8150213	8150557.10 8150569.10	50
48CZ 56C	8150046 8150082	8150058 8150094	8150070 8150106	8150522.10 8150534.10	8150154 8150190	8150166 8150202	8150178 8150214	8150558.10 8150570.10	60
48CZ 56C	8150047 8150083	8150059 8150095	8150071 8150107	8150523.10 8150535.10	8150155 8150191	8150167 8150203	8150179 8150215	8150559.10 8150571.10	80
48CZ 56C	8150048 8150084	8150060 8150096	8150072 8150108	8150524.10 8150536.10	8150156 8150192	8150168 8150204	8150180 8150216	8150560.10 8150572.10	100

For input/ output shaft overhung load and thrust load ratings, refer to pages 419-422.

▲ Consult Factory for other motor flanges available.



GR Series Dimensions

Styles: BMQ, BM, B

**CAST IRON
GR SERIES**

Style BMQ

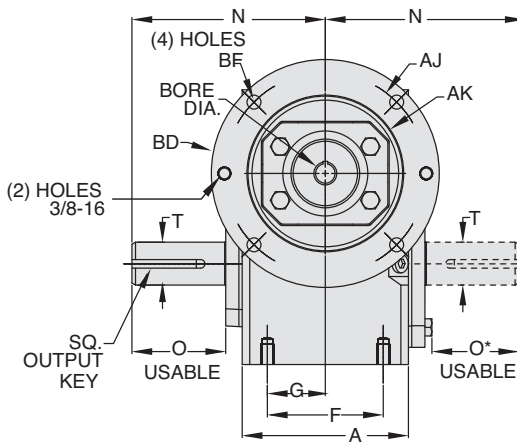
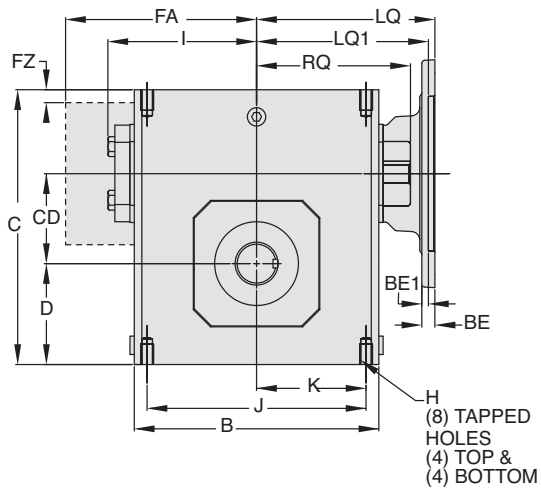

ASSEMBLIES

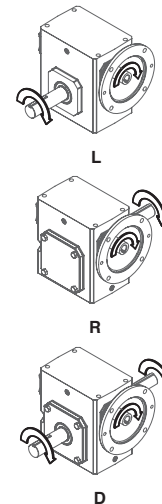

Style BM

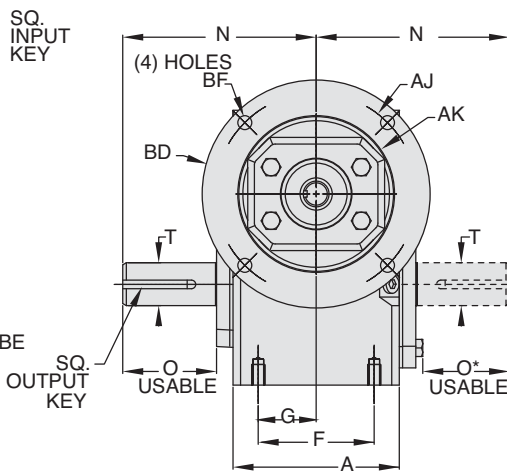
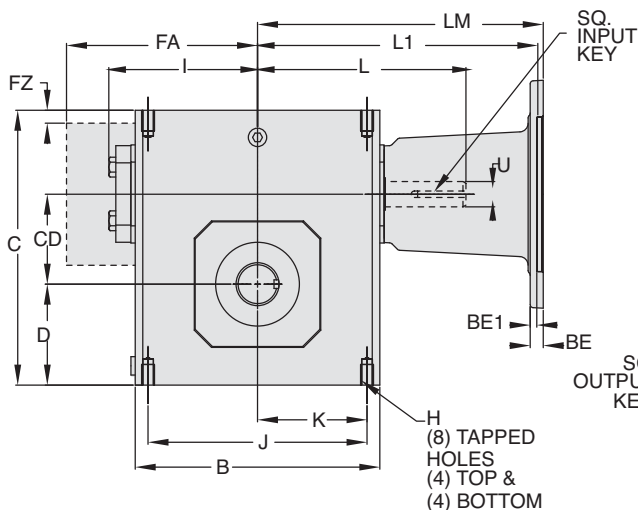

ASSEMBLIES

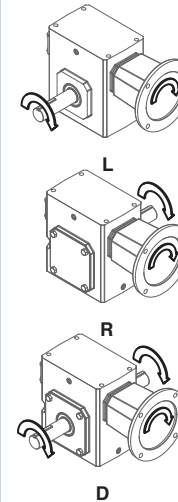

Style B

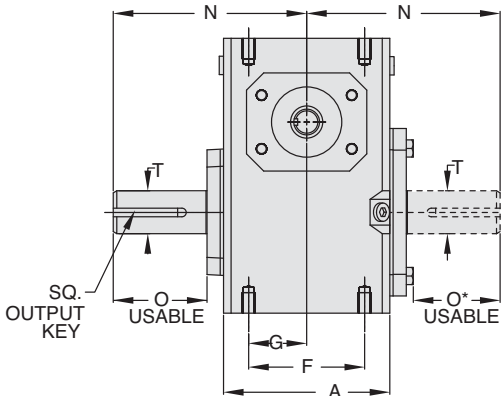
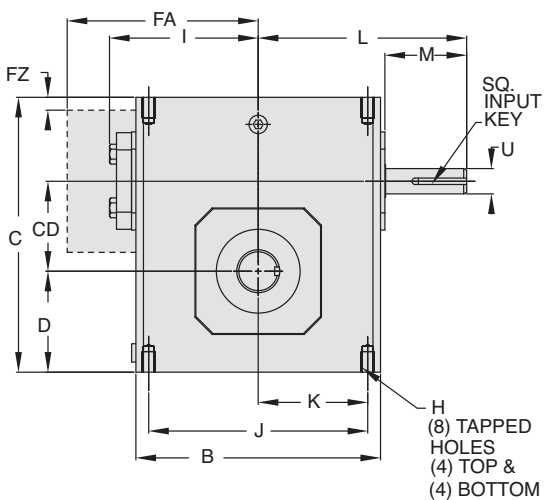

ASSEMBLIES

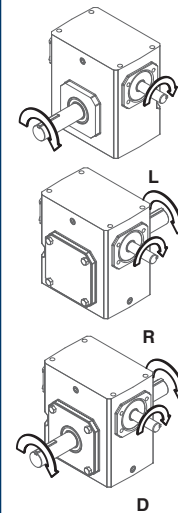

REVERSE ALL ARROWS
FOR OPPOSITE INPUT SHAFT
ROTATION. CONTACT FACTORY
FOR OTHER MOUNTINGS OR
ASSEMBLY POSITIONS.

Single Reduction
Worm Gear Reducers

Double Reduction
Worm - Worm Gear Reducers

Double Reduction
Helical - Worm Gear Reducers

WASHGUARD® Reducers
and GEAR+MOTOR™

Ratio Multipliers

Accessories and
Additional Capabilities



STYLE BMQ, BM, B DIMENSIONS (Inches)

Size	A	B	C	D	CD	F	FA ▼	FZ ▼	G	H		I	J	K	L	M	N	O	O*	T +0.000 -0.0015	U +0.000 -0.0015	Input Key*	Output Key
										Tap Size	Depth												
GR813	2.82	3.80	4.66	1.72	1.33	2.00	N/A	N/A	1.00	5/16-18 UNC	.50	2.61	3.25	1.63	3.82	1.76	4.00	2.16	1.94	.625	.500	1/8 X 1.00	3/16 X 1.50
GR815	3.44	4.88	5.38	1.91	1.54	2.75	N/A	N/A	1.38	5/16-18 UNC	.63	3.14	4.19	2.09	4.35	1.76	4.31	2.11	1.90	.750	.625	3/16 X 1.38	3/16 X 1.50
GR818	3.56	5.06	5.75	2.06	1.75	2.75	N/A	N/A	1.38	5/16-18 UNC	.63	3.24	4.19	2.09	4.45	1.76	4.31	2.05	1.84	.875	.625	3/16 X 1.38	3/16 X 1.38
GR821	3.81	5.80	6.38	2.28	2.06	▲	N/A	N/A	1.44	5/16-18 UNC	.63	3.61	▲	2.50	4.82	1.76	4.68	2.29	2.08	1.000	.625	3/16 X 1.38	1/4 X 1.44
GR824	4.06	6.12	6.94	2.50	2.38	2.88	N/A	N/A	1.44	3/8-16 UNC	.69	3.77	5.00	2.50	5.51	2.38	5.14	2.66	2.44	1.125	.750	3/16 X 1.63	1/4 X 1.75
GR826	4.84	7.12	8.00	2.94	2.63	3.38	N/A	N/A	1.69	3/8-16 UNC	.69	4.34	6.38	3.19	6.07	2.38	5.63	2.73	2.52	▲	.750	3/16 X 1.63	1/4 X 1.75
GR830	5.25	8.12	8.88	3.25	3.00	4.00	N/A	N/A	2.00	7/16-14 UNC	.88	4.84	7.00	3.50	6.57	2.38	6.75	3.60	3.36	1.250	.875	3/16 X 1.63	1/4 X 1.75
GR832	5.75	8.50	9.38	3.50	3.25	4.00	N/A	N/A	2.00	7/16-14 UNC	.88	5.02	7.50	3.75	6.76	2.38	7.06	3.66	3.42	▲	.875	3/16 X 1.63	▲
GR842	6.13	10.25	11.38	4.44	4.25	5.00	N/A	N/A	2.50	5/8-11 UNC	1.00	6.10	8.50	4.25	9.57	3.47	8.12	4.50	4.21	1.875	1.250	1/4 X 2.50	1/2 X 3.06
GR852	7.19	13.00	14.00	5.12	5.25	5.81	N/A	N/A	2.91	5/8-11 UNC	1.25	7.50	11.00	5.50	10.88	3.38	9.06	4.78	4.53	2.000	1.250	1/4 X 3.00	1/2 X 3.50
GR860	8.13	14.25	16.50	6.50	6.00	6.38	11.13	0.33	3.19	5/8-11 UNC	1.00	N/A	12.75	6.38	11.78	3.41	10.00	4.65	4.65	2.500	1.500	3/8 X 3.00	5/8 X 4.00
GR870	7.63	14.88	18.91	7.59	7.00	5.50	11.37	0.35	2.75	1-8 UNC	1.56	N/A	12.50	6.25	11.50	2.97	11.76	5.65	5.65	2.750	1.625	3/8 x 2.87**	5/8 x 4.00**
GR880	8.63	17.00	20.96	8.86	8.00	6.50	12.52	0.57	3.25	1-8 UNC	1.66	N/A	14.25	7.13	12.50	2.84	12.25	5.98	5.98	3.000	1.875	1/2 x 2.81**	3/4 x 4.50**
GR8100	9.53	20.88	25.47	10.36	10.00	6.88	14.69	0.51	3.44	1-1/4 -7 UNC	2.04	N/A	17.75	8.88	15.50	3.76	14.75	6.76	6.76	3.750	2.250	1/2 x 3.69**	7/8 x 5.00**

▲ See feature comparison chart.

FEATURE COMPARISON (821, 826, 832)

Size	Output Shaft Diameter Needed?	Mounting Footprint Needed?	Output Key Needed?	All Other Features	Grove Gear Flexaline Interchange	LEESON IRONMAN Interchange	Replace With Series Code Below:
821	Identical	(F)3.00" x (J)4.75"	Identical	Identical	✓	✓	GRG
		(F)2.88" x (J)5.00"					GRL
826	1.250"	Identical	Identical	Identical	✓	✓	GRG
	1.125"						GRL
832	1.500"	Identical	3/8 x 2.63	Identical	✓	✓	GRG
	1.375"		5/16 x 2.63				GRL

Motor Mounting Dimensions

NEMA DIMENSIONS (Inches)

Size	LM		180TC/210TC	L1	250TC	LQ		180TC	LQ1	210TC	250TC	RQ			
	48CZ	56C/140TC				48CZ/56C/140TC	180TC					210TC	250TC	180TC	210TC
GR813	5.63	6.07	N/A	N/A	3.46	N/A	N/A	N/A	3.09	N/A	N/A	N/A	N/A	N/A	N/A
GR815	6.16	6.60	N/A	N/A	3.99	N/A	N/A	N/A	3.62	N/A	N/A	N/A	N/A	N/A	N/A
GR818	6.26	6.70	N/A	N/A	4.09	N/A	N/A	N/A	3.59	N/A	N/A	N/A	N/A	N/A	N/A
GR821*	6.63	7.07	N/A	N/A	4.46	N/A	N/A	N/A	4.06	N/A	N/A	N/A	N/A	N/A	N/A
GR824	N/A	7.76	8.76	N/A	4.63	5.06	N/A	N/A	4.09	4.56	N/A	N/A	N/A	N/A	N/A
GR826*	N/A	8.32	9.32	N/A	5.19	5.62	N/A	N/A	4.82	5.13	N/A	N/A	N/A	N/A	N/A
GR830	N/A	8.82	9.82	N/A	5.95	6.15	6.56	N/A	5.32	5.63	6.06	N/A	N/A	N/A	N/A
GR832*	N/A	9.01	10.01	N/A	6.14	6.34	6.75	N/A	5.51	5.81	6.25	N/A	N/A	N/A	N/A
GR842	N/A	11.81	12.90	13.46	6.45	7.21	7.21	7.77	6.04	6.68	6.68	7.24	N/A	N/A	N/A
GR852	N/A	13.21	14.30	14.86	7.85	8.61	8.61	9.17	7.35	7.98	7.98	8.54	N/A	N/A	N/A
GR860	N/A	N/A	15.88	16.50	10.45	9.33	9.33	9.94	10.01	8.69	8.69	8.69	N/A	N/A	N/A
GR870	N/A	N/A	15.50	15.50	N/A	N/A	N/A	N/A	N/A	N/A	N/A	N/A	N/A	N/A	N/A
GR880	N/A	N/A	16.58	16.58	N/A	N/A	N/A	N/A	N/A	N/A	N/A	N/A	N/A	N/A	N/A

NEMA DIMENSIONS (Inches)

Frame	Ajb	AK	BD	BE	BE1	Bore Dia.	Keyway	BFB
48CZ	3.75	3.00	4.36	0.38	N/A	.500	1/8 X 1/16	0.28
56C	5.88	4.50	6.50	0.38	N/A	.625	3/16 X 3/32	0.41
140TC	5.88	4.50	6.50	0.38	N/A	.875	3/16 X 3/32	0.41
180TC	7.25	8.50	9.00	N/A	0.50	1.125	1/4 X 1/8	0.53
210TC	7.25	8.50	9.00	N/A	0.50	1.375	5/16 X 5/32	0.53
250TC	7.25	8.50	9.00	N/A	0.50	1.625	3/8 X 3/16	0.53

IEC B5 & B3/B5 METRIC DIMENSIONS (Inches)

Size	LQ1					RQ						
	D63D	D71D	D80D	D90D	D100LD/D112MD	D132D	D63D	D71D	D80D	D90D	D100LD/D112MD	D132D
GR813	2.62	2.65	2.89	N/A	N/A	N/A	2.45	2.47	2.71	N/A	N/A	N/A
GR815	3.15	3.18	3.42	N/A	N/A	N/A	2.98	3.00	3.24	N/A	N/A	N/A
GR818	3.25	3.28	3.52	N/A	N/A	N/A	2.95	2.97	3.21	N/A	N/A	N/A
GR821*	3.62	3.65	3.89	N/A	N/A	N/A	3.43	3.44	3.68	N/A	N/A	N/A
GR824	N/A	3.72	4.34	N/A	N/A	N/A	3.46	3.71	N/A	N/A	N/A	N/A
GR826*	N/A	4.28	4.90	4.90	5.30	N/A	N/A	4.09	4.72	4.72	5.07	N/A
GR830	N/A	4.78	5.41	5.41	5.88	N/A	N/A	4.59	5.22	5.22	5.57	N/A
GR832*	N/A	4.97	5.59	5.59	6.07	N/A	N/A	4.78	5.41	5.41	5.76	N/A
GR842	N/A	N/A	N/A	6.38	6.39	7.17	N/A	N/A	N/A	6.16	6.14	6.93
GR852	N/A	N/A	N/A	7.78	7.78	8.57	N/A	N/A	N/A	7.46	7.45	8.24

IEC B5 & B3/B5 METRIC DIMENSIONS (MM)

Frame	AJ	AK	BD	BE	Bore Dia.	Keyway	BF TAP	OD
D63D	115	95	117	10	11	4 X 2	M8 X 1.25	131
D71D	130	110	132	11	14	5 X 2.5	M8 X 1.25	146
D80D	165	130	165	15	19	6 X 3	M10 X 1.50	184
D90D	165	130	165	15	24	8 X 3.5	M10 X 1.50	184
D100LD/D112MD	215	180	216	18	28	8 X 3.5	M12 X 1.75	237
D132D	265	230	267	18	38	10 X 4	M12 X 1.75	290

- * Applies to double output shaft
- ** Key not provided with gear reducer. Keyway dimension shown.
- ◆ Keyway width by depth
- ⊙ Mounting holes rotated 45 degrees from positions shown on Size GR860, Style BM with frame sizes 180TC-250TC.
- 48CZ not available
- 180TC not available

- ◆ Metric IEC B5 input flange options are available only on quill input styles.
- * Dimensions same for GRG and GRL Series
- ⊙ Style B and BM only.
- ▼ Sizes 860-8100 are supplied with a fan. Dimensions refer to fan guard location.



WARNING For safety, purchaser or user should provide protective guards over shaft extensions and any couplings, sheaves and belts, sprockets and chains, etc., mounted thereon.

Single Reduction
Worm Gear Reducers

Double Reduction
Worm - Worm Gear Reducers

Double Reduction
Helical - Worm Gear Reducers

WASHGUARD® Reducers
and GEAR-HMOTOR™

Ratio Multipliers

Accessories and
Additional Capabilities