

Maximum Rating Tables

Size 860 • GR & EL Series



Single Reduction
Worm Gear Reducers

Double Reduction
Worm - Worm Gear Reducers

Double Reduction
Helical - Worm Gear Reducers

WASHGUARD® Reducers
and GEAR+MOTOR™

Ratio Multipliers

Accessories and
Additional Capabilities

Style B

Style H

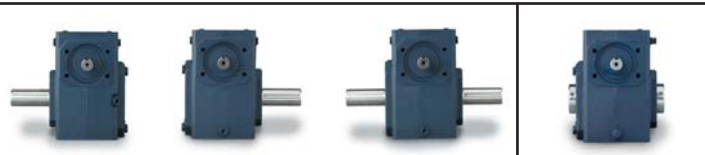

Size 860









Ratio	Input RPM	Output RPM	Input HP	Output HP	Output Torque (lb-in)	Left Hand Catalog No.	Right Hand Catalog No.	Double Extension Catalog No.	Hollow Output Catalog No.*
5	2500	500	39.83	38.29	4827	_8600085	_8600090	_8600095	_8600501.XX
	1750	350	35.10	33.70	6068				
	1170	234	29.94	28.69	7726				
7.5	100	20	6.203	5.581	17587	_8600086	_8600091	_8600096	_8600502.XX
	2500	333	34.20	32.60	6163				
	1750	233	29.98	28.52	7704				
10	1170	156	25.41	24.11	9740	_8600001	_8600008	_8600015	_8600503.XX
	100	13	5.018	4.371	20662				
	2500	250	28.53	26.90	6782				
15	1750	175	24.99	23.51	8467	_8600002	_8600009	_8600016	_8600504.XX
	1170	117	21.17	19.84	10687				
	100	10	4.198	3.542	22324				
20	2500	166	21.95	20.17	7628	_8600003	_8600010	_8600017	_8600505.XX
	1750	116	19.23	17.61	9515				
	1170	78	16.30	14.85	11996				
25	100	6.7	3.337	2.623	24797	_8600004	_8600011	_8600018	_8600507.XX
	2500	125	17.93	16.11	8123				
	1750	87	15.71	14.06	10127				
30	1170	58	13.32	11.84	12758	_8600005	_8600012	_8600019	_8600508.XX
	100	5.0	2.805	2.078	26194				
	2500	100	14.89	13.04	8219				
40	1750	70	13.06	11.378	10245	_8600006	_8600013	_8600020	_8600509.XX
	1170	46	11.094	9.582	12903				
	100	4.0	2.418	1.678	26436				
50	2500	83	12.73	10.87	8222	_8600007	_8600014	_8600021	_8600510.XX
	1750	58	11.177	9.486	10249				
	1170	39	9.507	7.989	12911				
60	100	3.3	2.143	1.400	26480	_8600008	_8600093	_8600098	_8600511.XX
	2500	62	9.922	8.119	8187				
	1750	43	8.722	7.083	10203				
80	1170	29	7.433	5.963	12848	_8600009	_8600094	_8600099	_8600512.XX
	100	2.5	1.761	1.042	26260				
	2500	50	8.226	6.417	8088				
100	1750	35	7.242	5.597	10079	_8600088	_8600093	_8600098	_8600511.XX
	1170	23	6.188	4.712	12691				
	100	2.0	1.544	0.823	25925				
100	2500	41	6.977	5.202	7869	_8600089	_8600094	_8600099	_8600512.XX
	1750	29	6.152	4.539	9808				
	1170	19	5.269	3.822	12352				
100	100	1.7	1.376	0.669	25283	_8600088	_8600093	_8600098	_8600511.XX
	2500	31	4.130	2.939	5962				
	1750	21	3.702	2.522	7264				
100	1170	14	3.315	2.122	9142	_8600089	_8600094	_8600099	_8600512.XX
	100	1.3	0.950	0.382	19249				
	2500	25	2.849	1.905	4802				
100	1750	17	2.571	1.635	5886	_8600089	_8600094	_8600099	_8600512.XX
	1170	11	2.323	1.376	7408				
	100	1.0	0.686	0.244	15389				

How To Build a Part Number For Size GR860, EL860

1. Select partial catalog number from the selection table
2. Replace leading “_” with series code (GR, EL)
3. For hollow output, replace “XX” suffix with bore code (see next page for codes)

Example:

Grove Gear IRONMAN, style B, 5:1 ratio, left hand output
GR-B860-5-L
GR8600085

	Style BM			Style HM	Style BMQ			Style HMQ	
									
NEMA C Input Flange ▲	Left Hand Catalog No.	Right Hand Catalog No.	Double Extension Catalog No.	Hollow Output Catalog No.*	Left Hand Catalog No.	Right Hand Catalog No.	Double Extension Catalog No.	Hollow Output Catalog No.*	Ratio
254-6TC	__8600130	__8600135	__8600140	__8600537.XX	__8600289	__8600301	__8600313	__8600597.XX	5
254-6TC	__8600131	__8600136	__8600141	__8600538.XX	__8600290	__8600302	__8600314	__8600598.XX	7.5
213-5TC 254-6TC	__8600043 __8600064	__8600050 __8600071	__8600057 __8600078	__8600527.XX __8600539.XX	__8600255 __8600291	__8600267 __8600303	__8600279 __8600315	__8600587.XX __8600599.XX	10
213-5TC 254-6TC	__8600044 __8600065	__8600051 __8600072	__8600058 __8600079	__8600528.XX __8600540.XX	__8600256 __8600292	__8600268 __8600304	__8600280 __8600316	__8600588.XX __8600600.XX	15
182-4TC 213-5TC	__8600024 __8600045	__8600031 __8600052	__8600038 __8600059	__8600517.XX __8600529.XX	__8600221 __8600257	__8600233 __8600269	__8600245 __8600281	__8600577.XX __8600589.XX	20
182-4TC 213-5TC	__8600102 __8600117	__8600107 __8600122	__8600112 __8600127	__8600518.XX __8600530.XX	__8600222 __8600258	__8600234 __8600270	__8600246 __8600282	__8600578.XX __8600590.XX	25
182-4TC 213-5TC	__8600025 __8600046	__8600032 __8600053	__8600039 __8600060	__8600519.XX __8600531.XX	__8600223 __8600259	__8600235 __8600271	__8600247 __8600283	__8600579.XX __8600591.XX	30
182-4TC 213-5TC	__8600026 __8600047	__8600033 __8600054	__8600040 __8600061	__8600520.XX __8600532.XX	__8600224 __8600260	__8600236 __8600272	__8600248 __8600284	__8600580.XX __8600592.XX	40
182-4TC	__8600027	__8600034	__8600041	__8600521.XX	__8600225	__8600237	__8600249	__8600581.XX	50
143-5TC 182-4TC	__8600028	__8600035	__8600042	__8600522.XX	__8600190 __8600226	__8600202 __8600238	__8600214 __8600250	__8600570.XX __8600582.XX	60
143-5TC 182-4TC	__8600103	__8600108	__8600113	__8600523.XX	__8600191 __8600227	__8600203 __8600239	__8600215 __8600251	__8600571.XX __8600583.XX	80
143-5TC 182-4TC	__8600104	__8600109	__8600114	__8600524.XX	__8600192 __8600228	__8600204 __8600240	__8600216 __8600252	__8600572.XX __8600584.XX	100

For input/ output shaft overhung load and thrust load ratings, refer to pages 419-422.

▲ Consult Factory for other motor flanges available.

* Catalog numbers are for hollow output shaft reducers.

When ordering, substitute the XX suffix with the required output bore code.

Available bore codes

Fraction Size	2"	2-3/16"	2-1/4"	2-7/16"	2-1/2"	2-11/16"	2-15/16"	3"	3-3/16"	3-7/16"
Decimal Size	2.000	2.188	2.250	2.438	2.500	2.688	2.938	3.000	3.188	3.438
Output Bore Code	32	35	36	39	40	43	47	48	51	55

Single Reduction
Worm Gear Reducers

Double Reduction
Worm - Worm Gear Reducers

Double Reduction
Helical - Worm Gear Reducers

WASHGUARD® Reducers
and GEAR+MOTOR™

Ratio Multipliers

Accessories and
Additional Capabilities



GR Series Dimensions

Styles: BMQ, BM, B

**CAST IRON
GR SERIES**

Single Reduction
Worm Gear Reducers

Double Reduction
Worm - Worm Gear Reducers

Double Reduction
Helical - Worm Gear Reducers

WASHGUARD® Reducers
and GEAR+MOTOR™

Ratio Multipliers

Accessories and
Additional Capabilities

Style BMQ

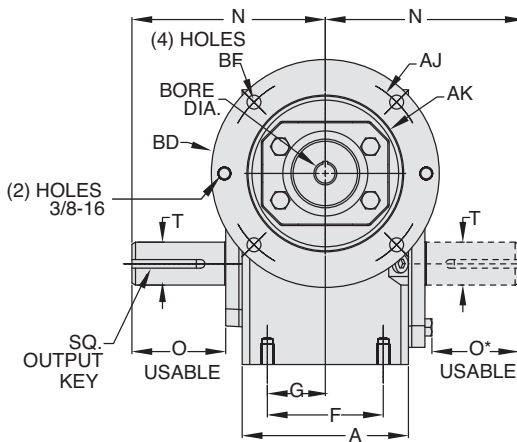
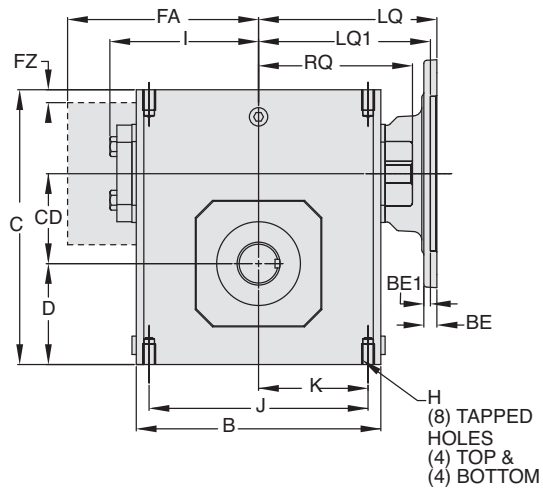

ASSEMBLIES

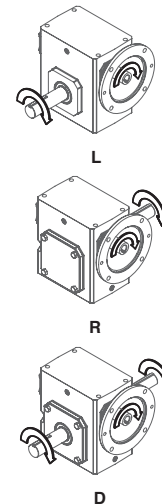

Style BM

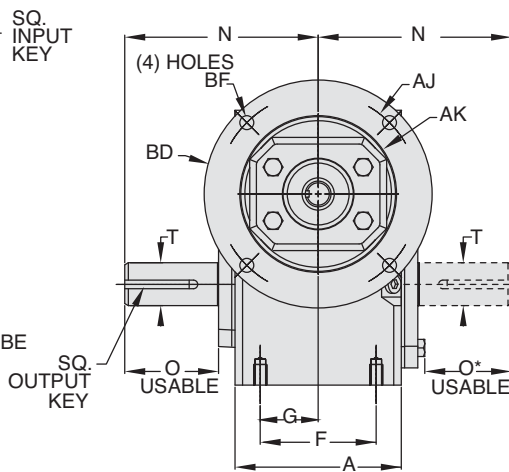
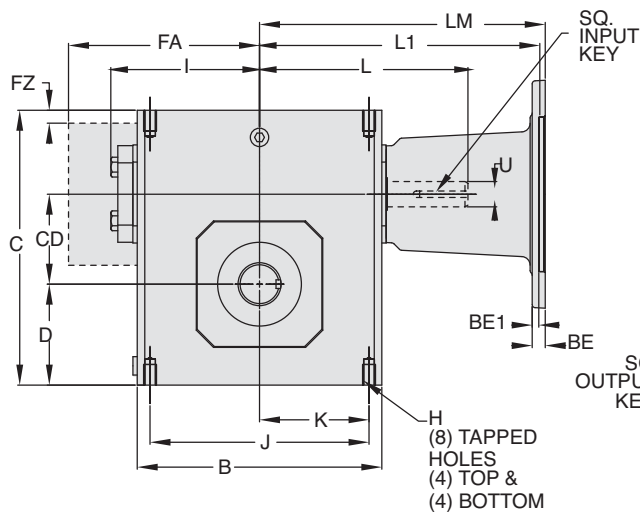

ASSEMBLIES

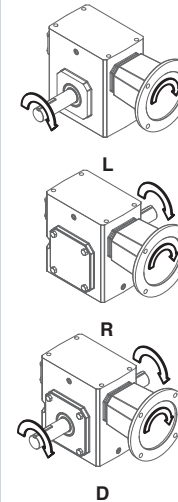

Style B

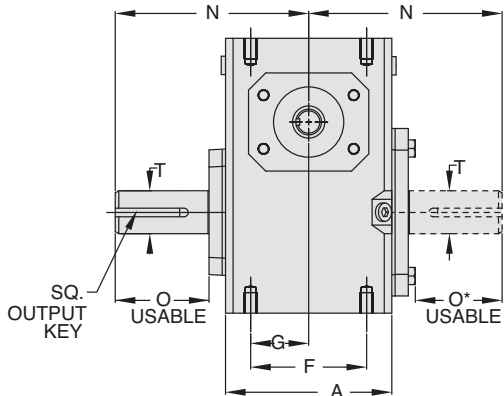
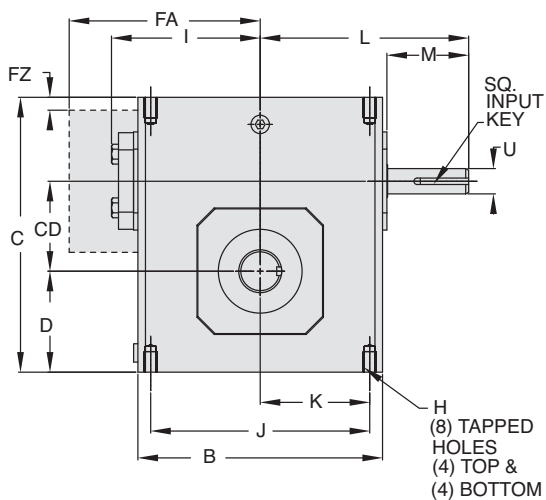

ASSEMBLIES

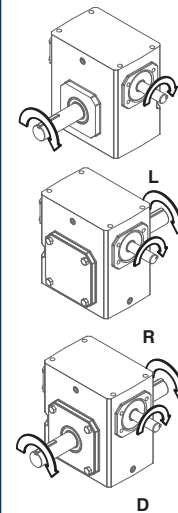

REVERSE ALL ARROWS
FOR OPPOSITE INPUT SHAFT
ROTATION. CONTACT FACTORY
FOR OTHER MOUNTINGS OR
ASSEMBLY POSITIONS.



STYLE BMQ, BM, B DIMENSIONS (Inches)

Size	A	B	C	D	CD	F	FA ▼	FZ ▼	G	H		I	J	K	L	M	N	O	O*	T +0.000 -0.0015	U +0.000 -0.0015	Input Key*	Output Key
										Tap Size	Depth												
GR813	2.82	3.80	4.66	1.72	1.33	2.00	N/A	N/A	1.00	5/16-18 UNC	.50	2.61	3.25	1.63	3.82	1.76	4.00	2.16	1.94	.625	.500	1/8 X 1.00	3/16 X 1.50
GR815	3.44	4.88	5.38	1.91	1.54	2.75	N/A	N/A	1.38	5/16-18 UNC	.63	3.14	4.19	2.09	4.35	1.76	4.31	2.11	1.90	.750	.625	3/16 X 1.38	3/16 X 1.50
GR818	3.56	5.06	5.75	2.06	1.75	2.75	N/A	N/A	1.38	5/16-18 UNC	.63	3.24	4.19	2.09	4.45	1.76	4.31	2.05	1.84	.875	.625	3/16 X 1.38	3/16 X 1.38
GR821	3.81	5.80	6.38	2.28	2.06	▲	N/A	N/A	1.44	5/16-18 UNC	.63	3.61	▲	2.50	4.82	1.76	4.68	2.29	2.08	1.000	.625	3/16 X 1.38	1/4 X 1.44
GR824	4.06	6.12	6.94	2.50	2.38	2.88	N/A	N/A	1.44	3/8-16 UNC	.69	3.77	5.00	2.50	5.51	2.38	5.14	2.66	2.44	1.125	.750	3/16 X 1.63	1/4 X 1.75
GR826	4.84	7.12	8.00	2.94	2.63	3.38	N/A	N/A	1.69	3/8-16 UNC	.69	4.34	6.38	3.19	6.07	2.38	5.63	2.73	2.52	▲	.750	3/16 X 1.63	1/4 X 1.75
GR830	5.25	8.12	8.88	3.25	3.00	4.00	N/A	N/A	2.00	7/16-14 UNC	.88	4.84	7.00	3.50	6.57	2.38	6.75	3.60	3.36	1.250	.875	3/16 X 1.63	1/4 X 1.75
GR832	5.75	8.50	9.38	3.50	3.25	4.00	N/A	N/A	2.00	7/16-14 UNC	.88	5.02	7.50	3.75	6.76	2.38	7.06	3.66	3.42	▲	.875	3/16 X 1.63	▲
GR842	6.13	10.25	11.38	4.44	4.25	5.00	N/A	N/A	2.50	5/8-11 UNC	1.00	6.10	8.50	4.25	9.57	3.47	8.12	4.50	4.21	1.875	1.250	1/4 X 2.50	1/2 X 3.06
GR852	7.19	13.00	14.00	5.12	5.25	5.81	N/A	N/A	2.91	5/8-11 UNC	1.25	7.50	11.00	5.50	10.88	3.38	9.06	4.78	4.53	2.000	1.250	1/4 X 3.00	1/2 X 3.50
GR860	8.13	14.25	16.50	6.50	6.00	6.38	11.13	0.33	3.19	5/8-11 UNC	1.00	N/A	12.75	6.38	11.78	3.41	10.00	4.65	4.65	2.500	1.500	3/8 X 3.00	5/8 X 4.00
GR870	7.63	14.88	18.91	7.59	7.00	5.50	11.37	0.35	2.75	1-8 UNC	1.56	N/A	12.50	6.25	11.50	2.97	11.76	5.65	5.65	2.750	1.625	3/8 x 2.87**	5/8 x 4.00**
GR880	8.63	17.00	20.96	8.86	8.00	6.50	12.52	0.57	3.25	1-8 UNC	1.66	N/A	14.25	7.13	12.50	2.84	12.25	5.98	5.98	3.000	1.875	1/2 x 2.81**	3/4 x 4.50**
GR8100	9.53	20.88	25.47	10.36	10.00	6.88	14.69	0.51	3.44	1-1/4 -7 UNC	2.04	N/A	17.75	8.88	15.50	3.76	14.75	6.76	6.76	3.750	2.250	1/2 x 3.69**	7/8 x 5.00**

▲ See feature comparison chart.

FEATURE COMPARISON (821, 826, 832)

Size	Output Shaft Diameter Needed?	Mounting Footprint Needed?	Output Key Needed?	All Other Features	Grove Gear Flexaline Interchange	LEESON IRONMAN Interchange	Replace With Series Code Below:
821	Identical	(F)3.00" x (J)4.75"	Identical	Identical	✓	✓	GRG
		(F)2.88" x (J)5.00"					GRL
826	1.250"	Identical	Identical	Identical	✓	✓	GRG
	1.125"						GRL
832	1.500"	Identical	3/8 x 2.63	Identical	✓	✓	GRG
	1.375"		5/16 x 2.63				GRL

Motor Mounting Dimensions

NEMA DIMENSIONS (Inches)

Size	LM		180TC/210TC	L1	250TC	LQ		180TC	LQ1	210TC	250TC	RQ			
	48CZ	56C/140TC				48CZ/56C/140TC	180TC					210TC	250TC	48CZ/56C/140TC	180TC
GR813	5.63	6.07	N/A	N/A	3.46	N/A	N/A	N/A	3.09	N/A	N/A	N/A	N/A	N/A	N/A
GR815	6.16	6.60	N/A	N/A	3.99	N/A	N/A	N/A	3.62	N/A	N/A	N/A	N/A	N/A	N/A
GR818	6.26	6.70	N/A	N/A	4.09	N/A	N/A	N/A	3.59	N/A	N/A	N/A	N/A	N/A	N/A
GR821*	6.63	7.07	N/A	N/A	4.46	N/A	N/A	N/A	4.06	N/A	N/A	N/A	N/A	N/A	N/A
GR824	N/A	7.76	8.76	N/A	4.63	5.06	N/A	N/A	4.09	4.56	N/A	N/A	N/A	N/A	N/A
GR826*	N/A	8.32	9.32	N/A	5.19	5.62	N/A	N/A	4.82	5.13	N/A	N/A	N/A	N/A	N/A
GR830	N/A	8.82	9.82	N/A	5.95	6.15	6.56	N/A	5.32	5.63	6.06	N/A	N/A	N/A	N/A
GR832*	N/A	9.01	10.01	N/A	6.14	6.34	6.75	N/A	5.51	5.81	6.25	N/A	N/A	N/A	N/A
GR842	N/A	11.81	12.90	13.46	6.45	7.21	7.21	7.77	6.04	6.68	6.68	7.24	N/A	N/A	N/A
GR852	N/A	13.21	14.30	14.86	7.85	8.61	8.61	9.17	7.35	7.98	7.98	8.54	N/A	N/A	N/A
GR860	N/A	N/A	15.88	16.50	10.45	9.33	9.33	9.94	10.01	8.69	8.69	8.69	N/A	N/A	N/A
GR870	N/A	N/A	15.50	15.50	N/A	N/A	N/A	N/A	N/A	N/A	N/A	N/A	N/A	N/A	N/A
GR880	N/A	N/A	16.58	16.58	N/A	N/A	N/A	N/A	N/A	N/A	N/A	N/A	N/A	N/A	N/A

NEMA DIMENSIONS (Inches)

Frame	Ajb	AK	BD	BE	BE1	Bore Dia.	Keyway	BFB
48CZ	3.75	3.00	4.36	0.38	N/A	.500	1/8 X 1/16	0.28
56C	5.88	4.50	6.50	0.38	N/A	.625	3/16 X 3/32	0.41
140TC	5.88	4.50	6.50	0.38	N/A	.875	3/16 X 3/32	0.41
180TC	7.25	8.50	9.00	N/A	0.50	1.125	1/4 X 1/8	0.53
210TC	7.25	8.50	9.00	N/A	0.50	1.375	5/16 X 5/32	0.53
250TC	7.25	8.50	9.00	N/A	0.50	1.625	3/8 X 3/16	0.53

IEC B5 & B3/B5 METRIC DIMENSIONS (Inches)*

Size	LQ1					RQ						
	D63D	D71D	D80D	D90D	D100LD/D112MD	D132D	D63D	D71D	D80D	D90D	D100LD/D112MD	D132D
GR813	2.62	2.65	2.89	N/A	N/A	N/A	2.45	2.47	2.71	N/A	N/A	N/A
GR815	3.15	3.18	3.42	N/A	N/A	N/A	2.98	3.00	3.24	N/A	N/A	N/A
GR818	3.25	3.28	3.52	N/A	N/A	N/A	2.95	2.97	3.21	N/A	N/A	N/A
GR821*	3.62	3.65	3.89	N/A	N/A	N/A	3.43	3.44	3.68	N/A	N/A	N/A
GR824	N/A	3.72	4.34	N/A	N/A	N/A	3.46	3.71	N/A	N/A	N/A	N/A
GR826*	N/A	4.28	4.90	4.90	5.30	N/A	N/A	4.09	4.72	4.72	5.07	N/A
GR830	N/A	4.78	5.41	5.41	5.88	N/A	N/A	4.59	5.22	5.22	5.57	N/A
GR832*	N/A	4.97	5.59	5.59	6.07	N/A	N/A	4.78	5.41	5.41	5.76	N/A
GR842	N/A	N/A	N/A	6.38	6.39	7.17	N/A	N/A	N/A	6.16	6.14	6.93
GR852	N/A	N/A	N/A	7.78	7.78	8.57	N/A	N/A	N/A	7.46	7.45	8.24

IEC B5 & B3/B5 METRIC DIMENSIONS (MM)

Frame	AJ	AK	BD	BE	Bore Dia.	Keyway	BF TAP	OD
D63D	115	95	117	10	11	4 X 2	M8 X 1.25	131
D71D	130	110	132	11	14	5 X 2.5	M8 X 1.25	146
D80D	165	130	165	15	19	6 X 3	M10 X 1.50	184
D90D	165	130	165	15	24	8 X 3.5	M10 X 1.50	184
D100LD/D112MD	215	180	216	18	28	8 X 3.5	M12 X 1.75	237
D132D	265	230	267	18	38	10 X 4	M12 X 1.75	290

- * Applies to double output shaft
- ** Key not provided with gear reducer. Keyway dimension shown.
- ◆ Keyway width by depth
- ⊙ Mounting holes rotated 45 degrees from positions shown on Size GR860, Style BM with frame sizes 180TC-250TC.
- 48CZ not available
- 180TC not available

- ◆ Metric IEC B5 input flange options are available only on quill input styles.
- * Dimensions same for GRG and GRL Series
- ⊙ Style B and BM only.
- ▼ Sizes 860-8100 are supplied with a fan. Dimensions refer to fan guard location.



WARNING For safety, purchaser or user should provide protective guards over shaft extensions and any couplings, sheaves and belts, sprockets and chains, etc., mounted thereon.

Single Reduction
Worm Gear Reducers

Double Reduction
Worm - Worm Gear Reducers

Double Reduction
Helical - Worm Gear Reducers

WASHGUARD® Reducers
and GEAR-HOTOR™

Ratio Multipliers

Accessories and
Additional Capabilities