

FRONT END DETAIL

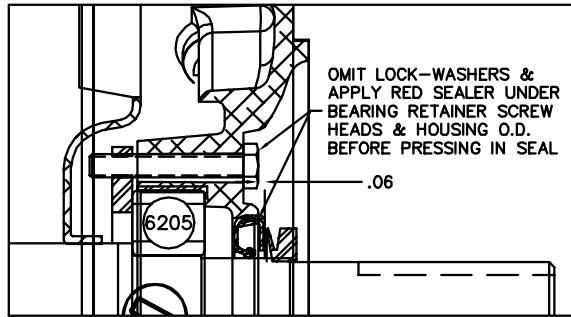

PULLEY END DETAIL

CUSTOMER IS RESPONSIBLE FOR DETERMINING THAT BALDOR'S PRODUCT WILL PERFORM SUITABLY IN THE INTENDED APPLICATION.

REV. DESC: UPDATE ENDPLATES AND NOTES		
REV. LTR: D	VERSION: 04	TDR: 00001074886
FILE: \AAA\00177\243	REVISED: 03:23:11 06/14/2018	BY: FGCHAH1
MTL: -		

BALDOR - RELIANCE®

VERT 143-5TC TEFC 35M WD (S/P 9) W/.75 NPT LEAD HOLE

SH 1 of 1